

DaVinci™  
GREENSMART ELECTRIC  
FIREPLACES



# DaVinci™

GREENSMART ELECTRIC  
FIREPLACES





## DAVINCI GREENSMART ELECTRIC FIREPLACES™

### The Pinnacle of Luxury, Holographic, Zero-Emission Electric Fireplaces

Discover the ultimate in holographic electric fireplace innovation with our DaVinci GreenSmart Electric Fireplaces™, where luxury seamlessly blends with technology.

Enjoy ultra-realistic flames brought to life through the reflection of three dimensional flames on and around our high definition logs, creating an unparalleled visual experience.

Take full control of your fireplace with smart features via our GreenSmart™ app, remote, or voice control, allowing you to customize flame style, colors and height, including controls for the glowing logs and live fuel bed.

With adjustable heat output, you can add warmth on cool days or enjoy a captivating flame display without heat for year-round enjoyment.

Effortless installation, versatile elegance, and a unique sensory experience make our GreenSmart Electric Fireplaces™ the epitome of efficiency and sophistication.



Experience the  
DaVinci GreenSmart  
Electric Fire

## LODGE FIRE

Bold flames impart a visual warmth like a traditional wood fire.

---



## URBAN FIRE

Contemporary fire in your choice of orange, yellow or white flames.

---



## AUDIO/VISUAL

Lodge and Urban fires both feature synchronized crackling fire audio and sparks with smoke to create a one-of-a kind electric fire.

---



# CUSTOMIZED LED LIGHTING



Choose color options and intensity for (1) live glowing logs, (2) downlight, (3) live fuel bed, (4) ambient lighting.

- Large split, high-definition logs
  - Highly-detailed mixed media live fuel bed
  - Fluted fireback
- 

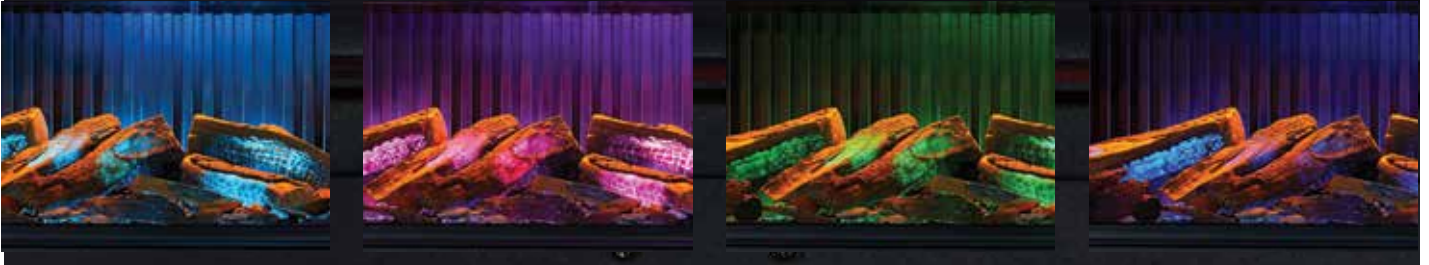

## AMBIENT LIGHTING (optional)



# FOUR DESIGN CONFIGURATIONS

The DaVinci GreenSmart Electric Fireplaces™ can be converted from Single-Sided to a Left Corner, Right Corner, or Bay Window configuration.

## Single-Sided



## Right or Left Corner



## Bay Window



# CONTROL - ENTERTAINMENT CENTER

Enjoy full control of your fireplace with our GREENSMART™ APP, REMOTE, GOOGLE HOME/ALEXA or our ON-BOARD MANUAL CONTROLS. Adjust flame style and height, flame color, down lighting, glowing logs, live fuel bed, crackling fire audio, sparks and smoke, room temperature, ambient room lighting, and Eco-Mode. Create and save your favorite settings.

---

## GreenSmart™ App



## DaVinci Remote



## Google Home/Alexa



## Manual Control



# HEAT OUTPUT CHOICE

120V - 4,800 BTUS/HR  
240V- 9,500 BTUS/HR

---

# EASY INSTALLATION

No limitations on materials or clearances to combustibles for your install.

You can install virtually anywhere with no venting required.

## DAVINCI GREENSMART ELECTRIC FIREPLACE™ DIMENSIONS

**Top View**

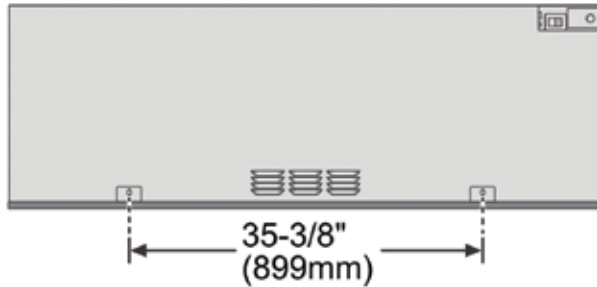

Always consult the Installation Manual before installing.

**Front View**

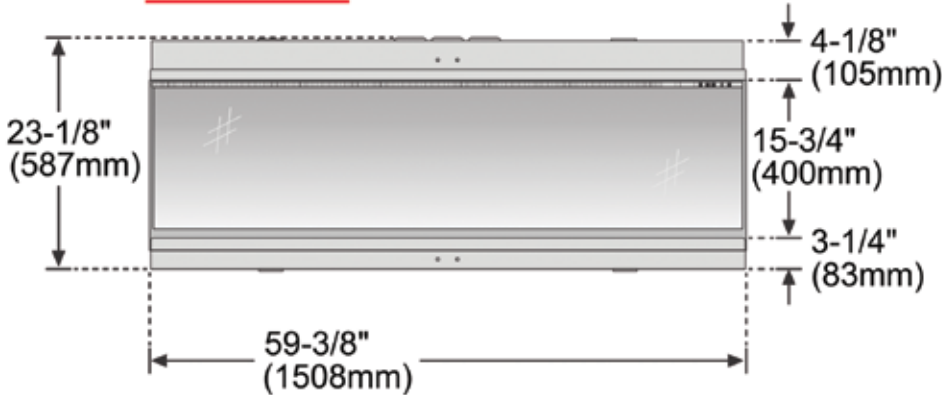

**Right View**

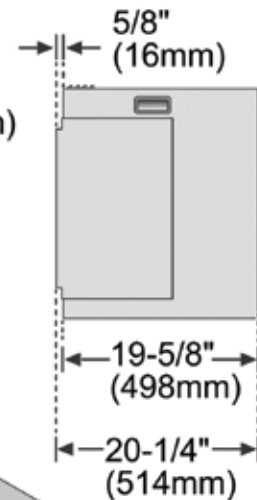

**Bottom View**

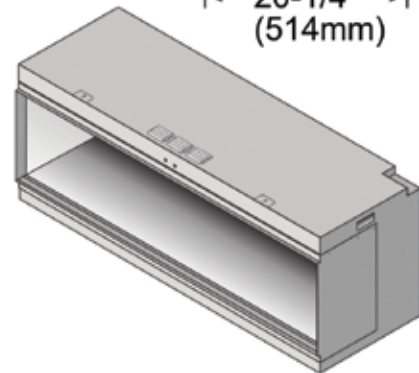
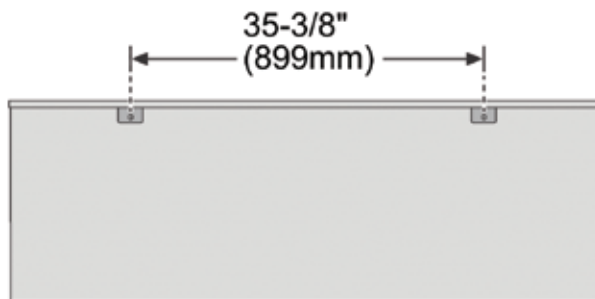

## PEACE OF MIND:

Two year warranty on parts and labor. See Owner's Manual for details.

**DaVinci™**  
GREENSMART ELECTRIC  
**FIREPLACES**

We reserve the right to make changes or modifications to products and specifications at any time, without prior notification. Refer to the owner's manual for detailed product and user instructions. Photos shown are for illustrative purposes only. The colors shown in the brochure are as accurate as possible, however some natural materials may vary due to the nature of the products.

© 2024 Travis Industries, Inc. - The House of Fire, Mukilteo, WA

SKU 98801125